

TRIOLOGY BUST

È la scelta più semplice ed economica per illuminare con estrema efficacia punti normalmente non raggiungibili dalla rete elettrica.

Contenitore in alluminio
Vetro temprato 4 mm
L70 >100.000 ore
Protezione IP65
12V DC
Peso 1.5 kg Trilogy; 8.2 kit PV

The easiest and less expensive way to properly light places not reached by the power grid.

Aluminum body
Tempered glass 4 mm
L70 >100.000 hrs
IP65 protection
12V DC
Weight 1.5 kg Trilogy; 8.2 kg kit PV



Applicazioni:

- Fermate bus
- Pensiline
- Cancelli
- Giardini
- Patii
- Chioschi
- Cartelli pubblicitari

ecc.

Ideal for:

- Bus stops
- Shelters
- Canopies
- Gates
- Gardens
- Patios
- Kiosks
- Advertising signs

etc.

Modello / Model		
nr. LED	Type	Current [mA]
5	R	115

Potenze / Power consumptions
10W ±5%

Ottiche disponibili / Available optics

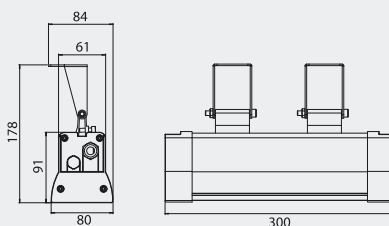
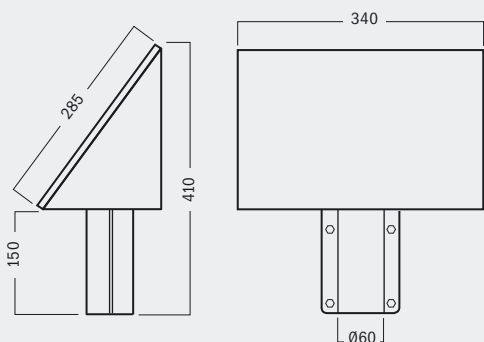
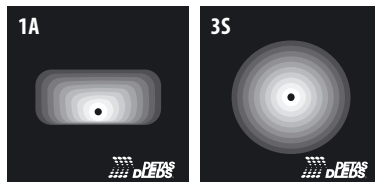

40

Sgaravatti Plant s.r.l.
via Panà, 56/B
35027 Noventa Padovana (PD) - Italia
www.sgaravattiplant.it - info@sgaravattiplant.it



Membro del consorzio ECOLIGHT - RAEE IT80200000001378 - Con riserva di modifiche S.E.&O. / Subject to change E.&O.E.

04-2012/VER.4.0



Trilogy bust

Kit fotovoltaico Trilogy

Trilogy fotovoltaic kit

12 VDC



An ISO 9001:2008 certificated company

Sgaravatti Plant s.r.l.
via Panà, 56/B
35027 Noventa Padovana (PD) - Italia
www.sgaravattiplant.it - info@sgaravattiplant.it